































# Low Noise Converter

## Nowadays FIT-Sat. 5.8GHz Low Noise Converter

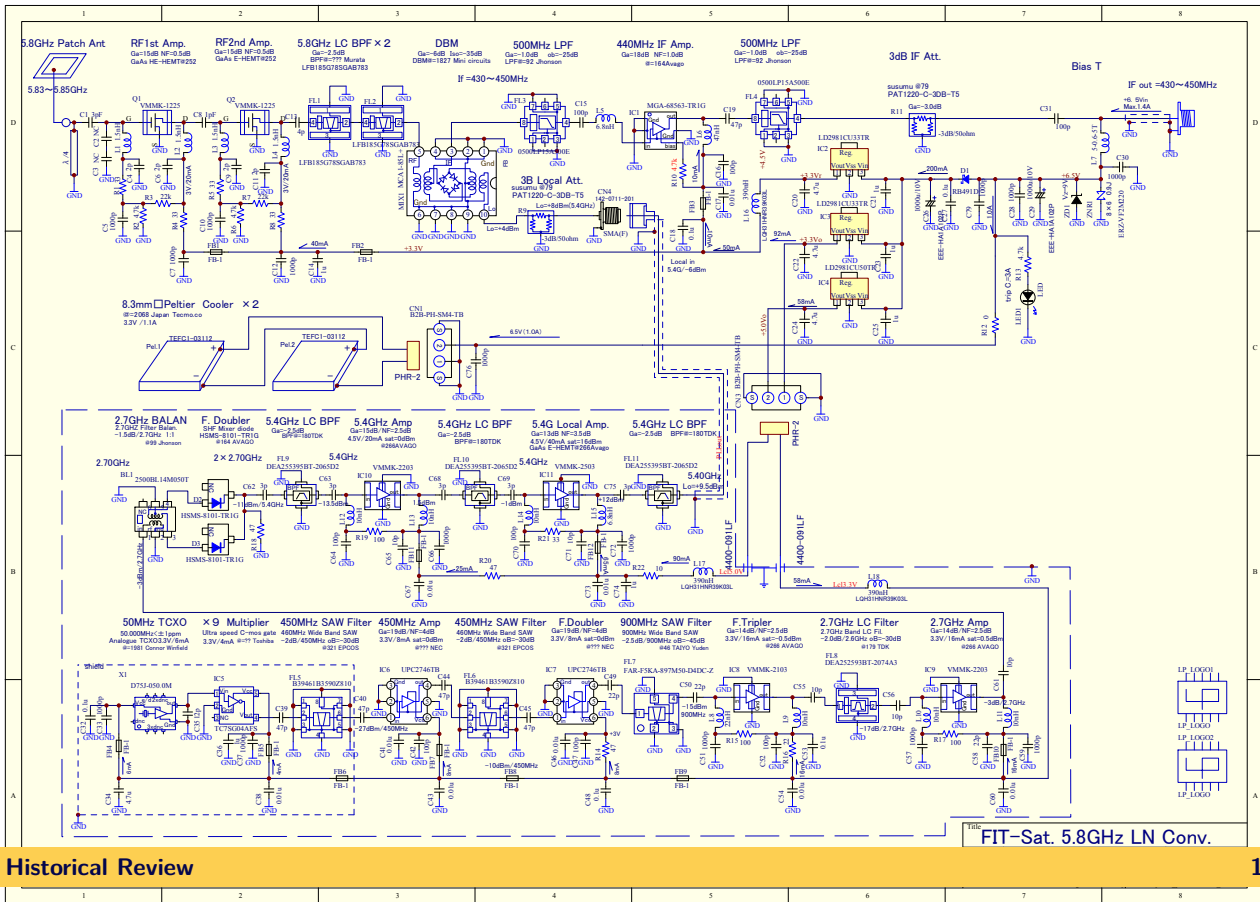

T.1 - Historical Review

### Notes

► FitSAT- A Small Artificial Satellite Developed at the Fukuoka Institute of Technology





# 5.4GHz Local Oscillator

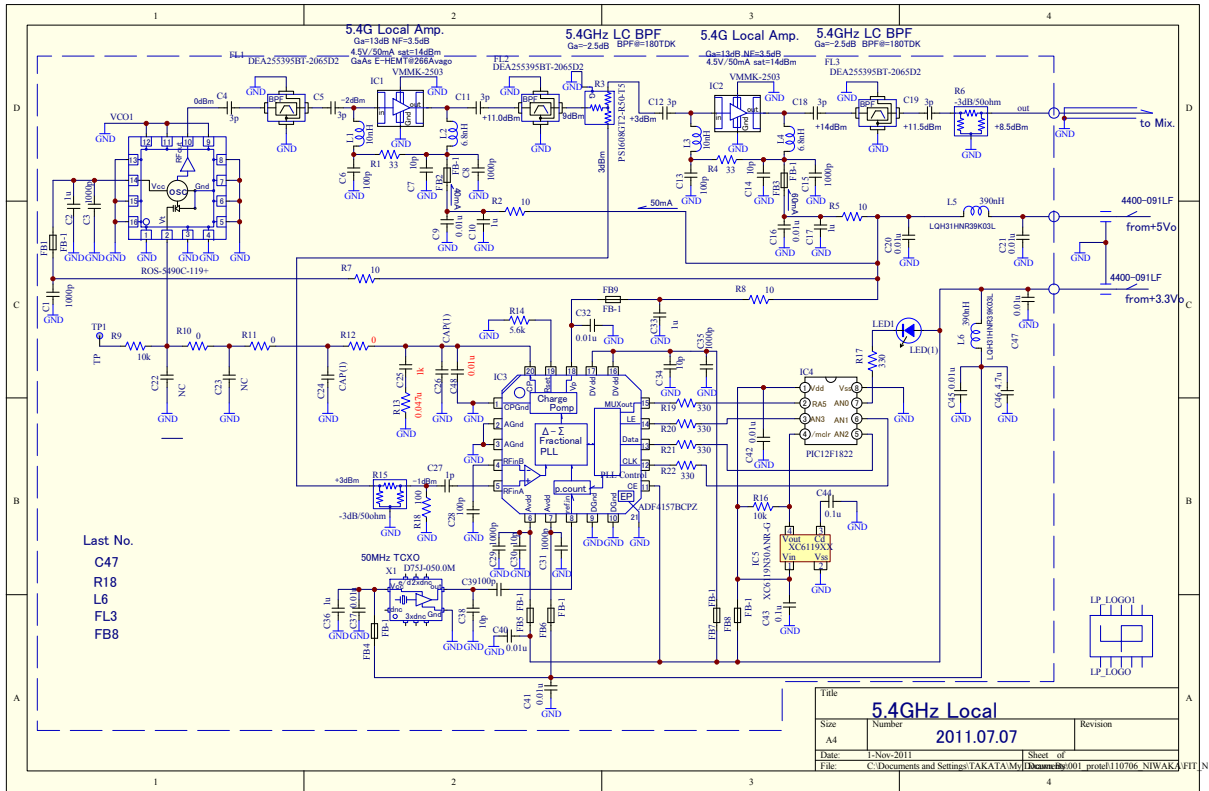

## Notes

