

# Satlink FB250+

*Fast and dependable satellite communications at sea*

## **USER / INSTALLATION MANUAL**



**LIST OF CONTENT:**

<i>REGULATORY INFORMATION</i>	<i>Error! Bookmark not defined.</i>
<i>SAFETY INSTRUCTIONS</i>	<i>5</i>
<i>SYSTEM CONFIGURATION</i>	<i>7</i>
<i>USER EQUIPMENT LISTS</i>	<i>8</i>
<i>1 FLEETBROADBAND USER EQUIPMENT</i>	<i>9</i>
<i>2 INSTALLATION OF THE USER EQUIPMENT</i>	<i>11</i>
<i>3 CONNECTIONS</i>	<i>20</i>
<i>4 GETTING STARTED ON THE SYSTEM</i>	<i>23</i>
<i>5 GLOSSARY</i>	<i>30</i>
<i>APPENDIX A OUTLINE DRAWINGS</i>	<i>31</i>

## REGULATORY INFORMATION

# **FC** Federal Communication Commission Notice

### **FCC Identifier: XGW-SLFB250PLUS**

#### USE CONDITIONS:

This device complies with part 15 of the FCC Rules. Operation is subject to the following two Conditions:

- (1) This device may not cause harmful interference, and
- (2) This device must accept any interference received, including interference that may cause undesired operation.

#### NOTE:

This equipment has been tested and found to comply with the limits for a Class B digital device, pursuant to Part 15 of the FCC Rules. These limits are designed to provide reasonable protection against harmful interference in a residential installation. This equipment generates uses and can radiate radio frequency energy and, if not installed and used in accordance with the instructions, may cause harmful interference to radio communications. However, there is no guarantee that interference will not occur in a particular installation.

If this equipment does cause harmful interference to radio or television reception, which can be determined by turning the equipment off and on, the user is encouraged to try to correct the interference by one of the following measures:

- Reorient or relocate the receiving antenna.
- Increase the separation between the equipment and receiver.
- Connect the equipment into an outlet on a circuit different from that to which the receiver is connected.
- Consult the dealer or an experienced radio/TV technician for help.

#### IMPORTANT NOTE: EXPOSURE TO RADIO FREQUENCY RADIATION

This Device complies with FCC radiation exposure limits set forth for an uncontrolled environment. The Antenna used for this transmitter must be installed to provide a separation distance of at least 100cm from all persons and must not be co-located or operating in conjunction with any other antenna or transmitter.

**FCC CAUTION:**

Any Changes or modifications not expressly approved by the manufacturer could void the user's authority, which is granted by FCC, to operate this Inmarsat Fleet Broadband Terminal, **Satlink FB 250+**

**Declaration of Conformity:**

Satlink A/S. Avda. de la Industria, 5328108 Alcobendas – Madrid , SPAIN  
manufacturer of this OEM product, that the product, brand name as **Satlink** and  
model: **Satlink FB 250+** , Inmarsat Fleet Broadband Terminal to which this declaration  
relates, is in conformity with the following standards and/or other normative  
documents:

ETSI EN 301 489-1, -19, -20, ETSI EN 301 444, EN 60945, IEC 60950 – 1 AND EN  
60950-1

We hereby declare that all essential radio test suite have been carried out and that the  
above named product is in conformity to all the essential requirements of Directive  
1999/5/EC. The Conformity Assessment procedure referred to Article 10 and detailed  
in Annex [III] or [IV] of Directive 1999/5/EC has been followed with involvement of the  
following notified body(ies):

TIMCO ENGINEERING, INC., P.O BOX 370, NEW BERRY, FLORIDA 32669.

Identification mark: 1177 (Notified Body number)



The technical documentation relevant to the above equipment are held at:

- Addvalue Innovation Pte Ltd., 8, Tai Seng Link, Level 5 (Wing 2), Singapore 534158.
- Signed by Mr. Jens Heinsdorf, Chief Technology Officer on November 04, 2014



## SAFETY INSTRUCTIONS



For the sake of safety and protection, read the manual before attempting to use the FBB User Equipment (UE).

The following general safety precautions must be observed during all phases of operation, service and repair of this equipment. Failure to comply with these precautions or with specific warnings elsewhere in this user guide violates safety standards of intended use of the UE.

Addvalue Innovation Pte Ltd assumes no liability for the customer's failure to comply with these requirements.

### Hazard Symbols

<p><b>Heated Surfaces</b></p> 	<p>Avoid touching those areas of the UE that are being marked with this symbol otherwise it may result in injury.</p>
<p><b>Antenna Radiation Warning and Distance to other Radiation Equipment</b></p> 	<p>For safety reasons, all personnel must keep at least 2 meters from the antenna.</p>
<p><b>Power Supply</b></p> 	<p>Turn off the power at the mains switchboard before beginning of the installation.</p> <p>Confirm the power voltage is compatible with voltage rating of the UE. It is highly recommended to use +24V DC power line, provided that it is available on the vessel.</p> <p>In case of unavailability of +24V DC power line provided by the vessel, an external AC/DC power supply of 115/230V AC with its output of +24V DC can be used.</p> <p>Note: The requirements of the AC/DC power supply should take care of high surge current of 25A at 24V DC for 1ms.</p>

<p><b>Grounding, cables and connections</b></p> 	<p>The chassis of the equipment must be connected to an electrical ground. This will minimise electric shock and mutual interference. In short, the UE must be grounded to the vessel.</p>
<p><b>Service</b></p> 	<p>Do not attempt to access to the interior of the UE. Only qualified personnel authorized by its manufacturer may perform service. Failure to comply with this rule will result in the warranty void.</p> <p>Under certain conditions, dangerous voltages may exist even with the power cable removed. To avoid injuries, always disconnect power before accessing the UE.</p>

**Equipment Ventilation**

To ensure adequate cooling of the equipment, 5-centimeter of unobstructed space must be maintained around all sides of the unit except the bottom side. The ambient temperature range of the equipment is: -25 °C to +55 °C.

**Fire Precautions**

The equipment shall not be operated in the presence of flammable gases or fumes as well as any explosive atmosphere. Operation of any electrical equipment in such an environment constitutes a definite safety hazard.

**Obtaining Licensing For Inmarsat Transceivers**

Under rights given under ITU Radio Regulations, local telecommunications administrations establish and enforce national rules and regulations governing types of emissions, power levels, and other parameters that affect the purity of signal, which may be radiated in the various frequency bands of the radio spectrum.

To legally operate Inmarsat equipment, it is necessary to obtain permission from the local telecommunications regulatory authorities of the country you are operating from. Using your equipment in any country without permission causes you to run the risk of confiscation of the equipment by the local authorities. The normal procedure to bring such equipment into another country is to apply for a license before travel. If a license has not been obtained before travel, the equipment may be put in to storage by local authorities until such time license is obtained.

SYSTEM CONFIGURATION

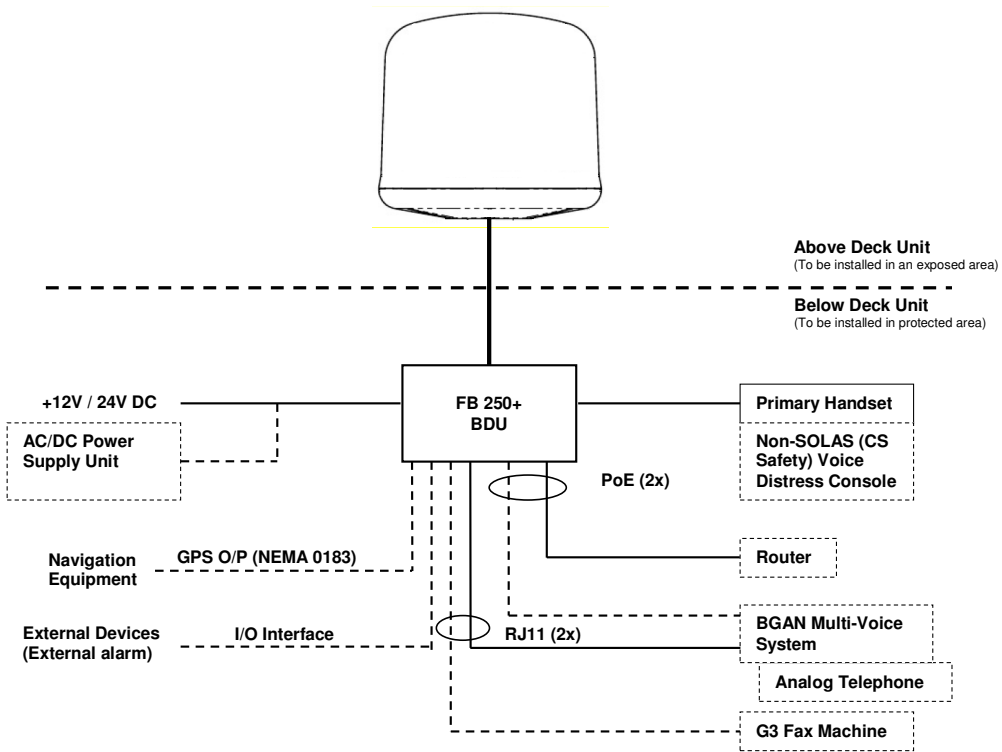

Solid line refers to the basic configuration.

## USER EQUIPMENT LISTS

### FB 250+ Complete Standard Package

Description	Order Code
FB 250+ Terminal	FX15-9TE00-01

### FB 250+ Standard Accessories

Description	Order Code
FB 250+ FleetBroadband Primary Handset	FX15-0PH00-02
Ethernet Cable (1.5m)	FX50-0CE02-01
Telephone Cord (1.8m)	FX50-0CT02-01
Handset Wall Mount Cradle	SG5000/WMC
Power Cable (1.8m)	FX15-0CP02-01
GPIO Cable 8-pin (1m)	FX50-0CO01-01

### FB 250+ Optional Accessories

Description	Order Code
Antenna Pole Mount with Mounting Kit	FX25-0PM00-01
Serial Port Cable for GPS O/P(1.8m)	FX50-0CG02-01
Handset Ext Cable Circular 10-pins (5m)	SC11-0CX05-01



## **1 FLEETBROADBAND USER EQUIPMENT**

### **1.1 Introduction**

The FBB UE consists of three units;

- Below Deck Unit (BDU) which is a communication unit
- Above Deck Unit (ADU) which is an antenna unit
- Wired Primary handset with cradle

### **1.2 Above Deck Unit**

The ADU is a 3-axis controlled antenna unit which is self-tracking.



The radome covers the antenna unit, which is comprised of

- Antenna Module
- RF and GPS Module
- Rotary Joint
- Antenna Pedestal

The antenna module includes a low noise amplifier (LNA), high power amplifier (HPA), and tracking receiver circuitry. All the signals and DC power pass through a single coaxial antenna cable, which connects the ADU to the BDU.

### 1.3 Below Deck Unit

The BDU is the heart unit of the FBB UE. It has several interface ports and handles all communication links between the ADU, primary handset and the local communication devices such as analog telephone, computer, network equipment, navigation equipment etc.



The BDU is supplied by +12V or +24V DC power supply and it supplies a step-up voltage of 40V ~ 43V DC to the ADU via a single RF / coaxial antenna cable.

### 1.4 Wired Primary Handset with Cradle

The wired Primary Handset has a colour liquid crystal display (LCD) and keypad for making and receiving normal voice calls and sending SMS, which both are similar as any mobile phone. The handset is provided with a cradle.

Additionally, it can serve as a remote access for an user to access various configuration supported by the BDU.



The Primary Handset's connector is plugged into the BDU's primary handset port. It is powered directly from the BDU.

## 2 INSTALLATION OF THE USER EQUIPMENT

### 2.1 Installation of ADU

#### 2.1.1 Overview

In general, any obstructing objects like mast near the antenna unit can block reception or transmission from a satellite's line of sight. In addition, RF radiation emitting from the antenna will affect human body. When selecting a mounting location, it is important to ensure that the antenna unit shall be free of severe vibration and shock and heat and smoke from funnel. More guidelines will be detailed in the next sections.

#### 2.1.2 Radiation Hazard

Radio wave can pose hazard to human body. Safe distances are changed, subjected to country and ship construction. There is no standard formula to calculate safe distance. The below guidelines are to be noted.

#### FB 250+ ADU

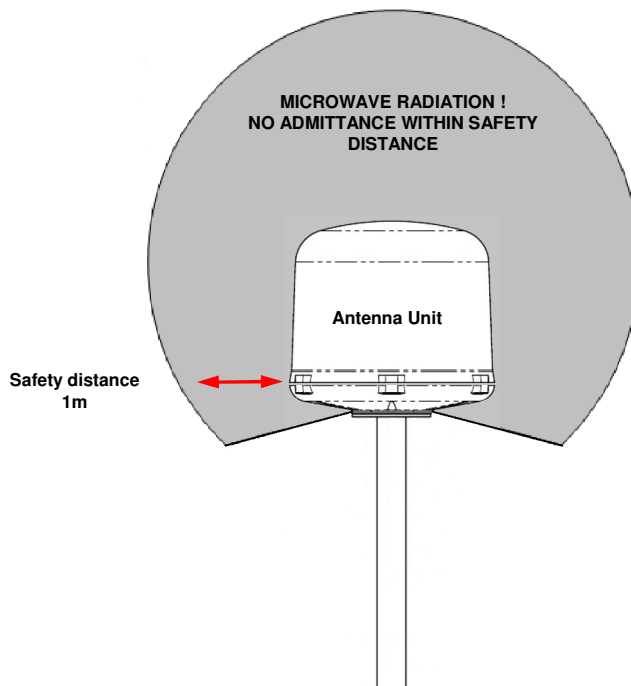

**WARNING:** Keep away from the antenna radome at the mentioned safe distance when it is transmitting. Microwave radiation can be harmful to human body, particularly the eyes.

**2.1.3 Interference**

The antenna unit must be mounted as far as possible away from the ship's radars, MF/HF antennas, communication/navigation antennas, VSAT system and any high power radio transmitter (including other Inmarsat-based system).

As for a ship's radar (see below), it is difficult to provide the exact minimum distance between a radar and the antenna unit due to different type of radars in terms of power, radiation pattern and operating frequency band.

The antenna unit is recommended to be at least 5-meter away from the radar position and at least  $\pm 15^\circ$  from the radar's vertical beam.

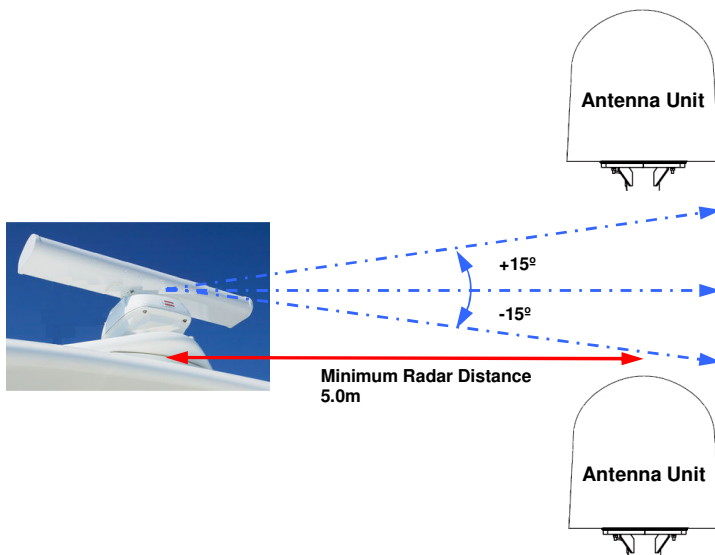

### **2.1.4 Obstruction**

The mounting position of the antenna unit especially its line-of-sight are possibly obstructed by any large obstacle in a vessel or ship. This will result in the degradation of the satellite signal. It is very important to choose the ideal installation site on the upper deck to minimise the satellite blocking.

Examples of the large obstacles are:

- Upper Deck and funnel of ship



- VSAT with its radome



- Large mechanical structure mounting of radars



## FB 250+ Installation Manual

With the understanding of the large obstacle, it helps in the decision of the installation site with the reduction of the physical obstruction.

### 2.1.5 Antenna Mast

The antenna unit should be located at least 3-meter away from the ship's mast having a diameter of less than 15cm.

**For FX 150 ADU**, if the antenna mast is available on the vessel and it is free of any shock or vibration, its physical size shall support the weight and size of that FX 150 ADU. An example of the antenna mast is illustrated as below.



- The mast should provide the internal hole for the installation of the coaxial cable.
- The flange (known as the top plate) of the mast shall meet the dimensions of the ADU's mounting base, where there are 6 holes.
- The rubber gasket is required to be inserted between the ADU mounting base and the flange.

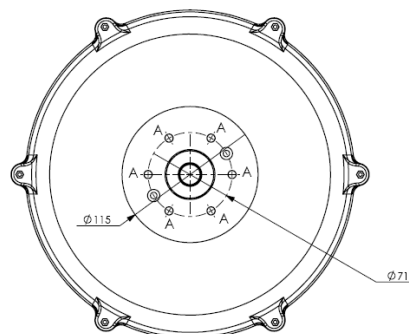

**A : Use M6x20 Hex Head Screw bolts (6x) into the threaded holes of ADU Mounting Base for mounting the ADU.**

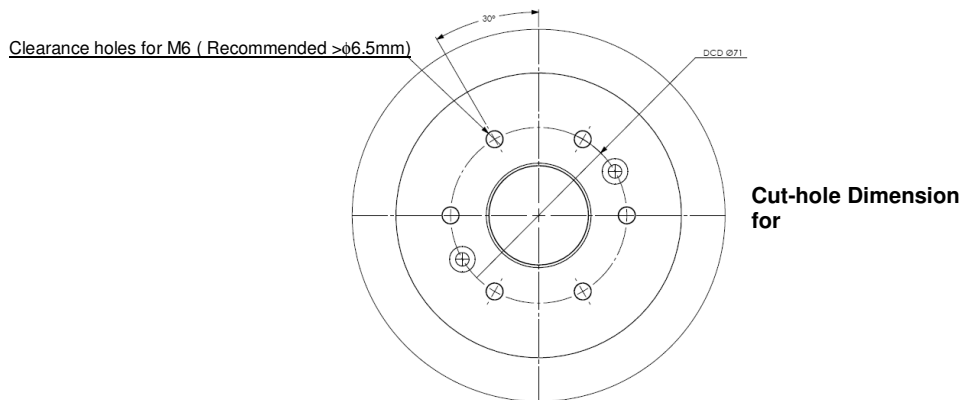

In case of the existing mast's flange in a vessel or ship does not fit the ADU's mounting base's holes, a mechanical adaptation flange/plate is to be designed and custom-made, which acts as an interface between the existing mast and the ADU.



**Custom-made  
mechanical adaptation  
flange**

### 2.1.6 Installing Antenna Unit

The antenna unit is carefully unpacked and checked for any damage.

#### For FB 250+ Antenna Unit,

The procedure of the installing the antenna unit is as follow:

- Attach the coaxial cable to the RF connector of the antenna unit's bottom.
- Position the antenna unit to the mounting location.
- Ensure the connection of the coaxial cable and wrap it with self-adhesive tape for water-proofing.
- Put the antenna unit on the mounting flange and use 6 sets of M6 x 20 Hex head screw bolts with flat washers into the threaded holes of ADU mounting base via the mounting flange's holes.

## FB 250+ Installation Manual

---

- ⇒ Tighten the flat washers and screw to the antenna unit in order to secure it to the mounting flange.

Alternatively it can be mounted on the long pole. The physical dimension of a long pole shall be preferably at 2 meter height with its diameter ranges from Ø35 to Ø 50mm. In addition, the optional pole mount kit is available for the installation of the ADU onto the long post.

### 2.1.1 Antenna Cable Recommended Specifications

The table below shows the recommended cable types and maximum cable lengths.

Antenna Cable Type	Maximum Cable length
TM LMR 195	18m
TM LMR 240	25m
TM LMR-400	50m
TM LMR-600	75m

Refer to the table for cable termination type.

FleetBroadband Model	Cable Termination
FX 150	N-Male to TNC-Male
FX 250 / FX 500	N-Male to N-Male

Check the datasheet of the selected cable to ensure that cable meets the following specifications.

- Antenna cable RF-attenuation between ADU and BDU at 1.6GHz does not exceed 10 dB, including connector.
- Antenna cable loop DC-resistance max: 1  $\Omega$ .
- Impedance of the cable is 50ohms.

## 2.2 Installation of BDU

The BDU's pretty box is unpacked and the following items should be checked whether they are present:

- ⇒ BDU
- ⇒ 1 meter Wired Primary Handset with cradle
- ⇒ 1.5 meters Ethernet Cable
- ⇒ 1.8 meters Telephone Cord
- ⇒ 1.8 meters DC Power Cable
- ⇒ 1 meter GPIO (General Purpose Input / Output) cable
- ⇒ Hardcopy Quick Start Guide
- ⇒ CD format User manual



## FB 250+ Installation Manual

---

The following important notes are to be followed for the selection of a location before installing the BDU:

- The unit is not water proof and it has to be kept away from water splash.
- The ambient temperature and humidity in the selected location must meet the requirements given in the unit's specification.

Ambient Temperature	-25°C to +55°C
Relative Humidity	Up to 95% at +40°C.

- The unit shall be kept away from direct sunlight.
- The unit shall be placed away from any high-vibrated and shock areas (for example, motor engine and generator) as far as possible.
- The unit shall be kept away from any equipment.
- The unit has to follow the recommended compass safe distance of 1m to prevent interference to a magnetic compass.
- For maintenance and checking, the unit's location has sufficient space at its sides and rear.

The BDU can be installed on a desktop, bulkhead, top ceiling or under captain's console.

The procedure of installing the BDU is simple as follow:

- Place the BDU on the desired installation area.
- Look for the holes of the BDU's mounting brackets.

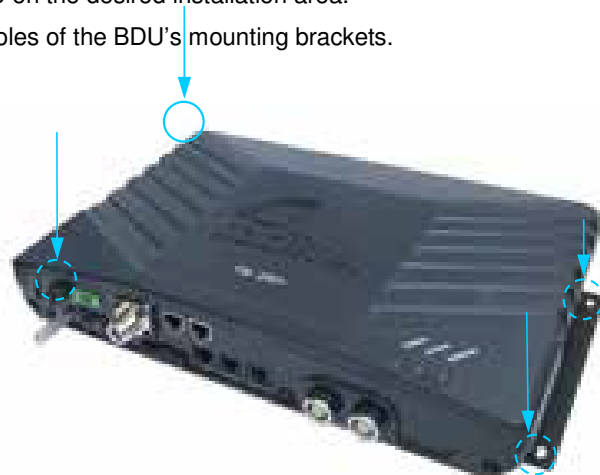



- ➔ Fix the holes of mounting brackets with four M4x12mm self-tapping or machined screws so that the BDU is being secured.

### **2.3 Installation of Primary Handset**

The primary handset is provided with cradle. It can be mounted on a desktop, bulkhead, top ceiling or under captain's console as similar as the BDU.

The primary handset is to be separated from its cradle so that the cradle can be fixed with the M5 x 12mm self-tapping screws.

The procedure of installing the cradle is simple as follow:

1. Separate the handset from the cradle and remove the plastic cover of the cradle.
2. Position the cradle on the mounting areas.
3. Fix the cradle with M5 x 12mm self-tapping screws, which are supplied.
4. Reattach the plastic cover onto the cradle.
5. Secure the handset onto the cradle.

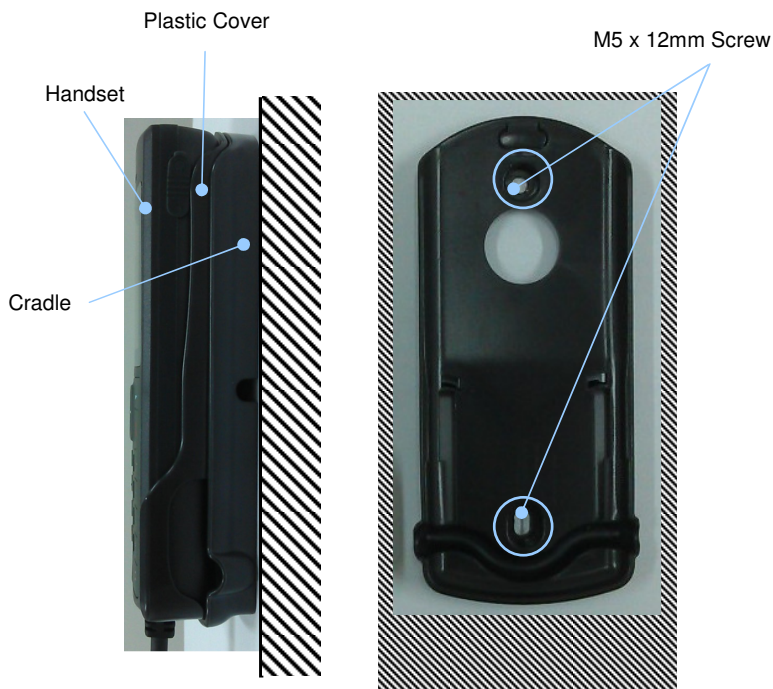

### 3 CONNECTIONS

Below is the interconnection diagram of FB UE with the cables.

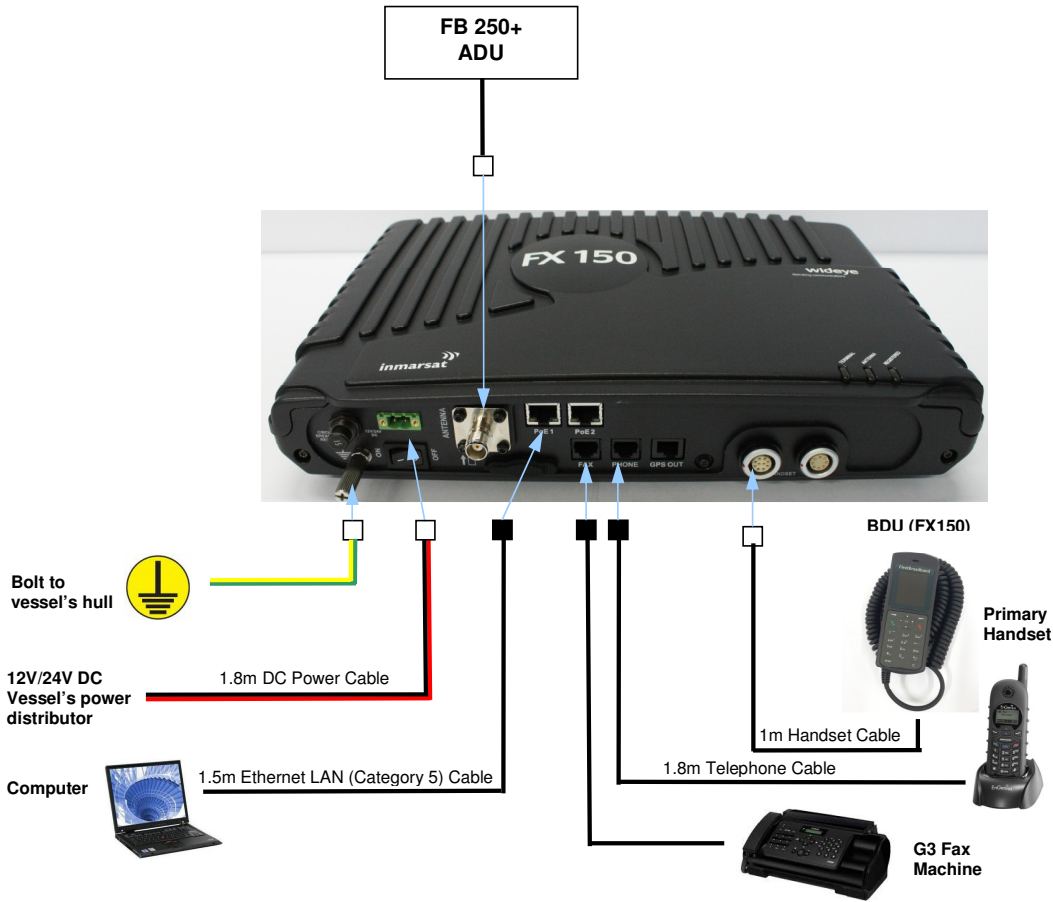

### 3.1 BDU's Outputs Connection

The additional information of the output ports of GPS and GPIO.

#### 3.1.1 GPS Output RJ11 (Offset) Connector

The BDU has a The Transceiver Unit has a GPS output RJ11 (Offset) connector for outputting the GPS data in NMEA0183 format.

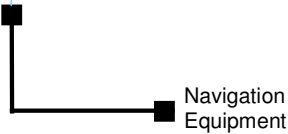
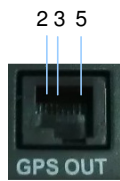

GPS Output Pinout	
Pin No.	Signal
Pin 5	TX
Pin 2	RX
Pin 3	GND

RS232 Pinout	
Pin No.	Signal
Pin 2	RX
Pin 3	TX
Pin 5	GND



### 3.1.2 GPIO Output

The BDU has a dedicated circular connector to provide GPIO (General Purpose Input/Output) interface to the external devices.



GPIO Port Pinout

GPIO Port Pin	Signal Name	Description of Signal	Color Code
GPIO-1	RES_1	Reserve line 1	Black
GPIO-2	GND	Ground line	Brown
GPIO-3	LED_ENABLE	To enable LED ON	Red
GPIO-4	REM_ON_OFF	Remote ON / OFF	Orange
GPIO-5	BUZZER	Buzzer	Yellow
GPIO-6	GND	Ground line	Green
GPIO-7	TX_OFF	To turn off Transmitter off	Blue
GPIO-8	+5V_DC	+5V DC Output with up to 100mA	Purple

All wires for the GPIO connector shall use AWG 24 unscreened wire type.

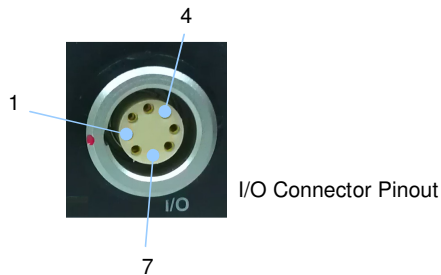

### 3.1.3 Grounding Stud

The BDU has a grounding stud with a locking screw for the earth cable (with its colors of green and yellow) with its UE lug. It is recommended to include spring washers to secure the UE lug to the grounding stud.

## 4 GETTING STARTED ON THE SYSTEM

### 4.1 Installing the SIM card

The terminal requires a SIM card to access the Inmarsat's FBB network and it is provided by your Airtime Service Provider. Insert the SIM card to the BDU as follow:

- Tilt up the SIM card slot's rubber cover.

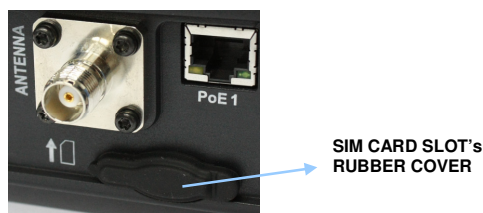

- Position the SIM card with its gold-contacts facing down. (There is a symbol of SIM Card with its arrow on the front panel. It will ensure the correct orientation of the SIM Card when it is being inserted. )

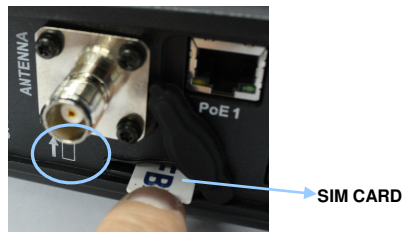

- Push the SIM card gently until it is being clicked and locked in place. A screwdriver can help to push the SIM card if the SIM card cannot be inserted properly.
- Tilt down the SIM card cover to its original position.

## 4.2 Powering up the terminal

Formatted: Not Highlight

### 4.2.1 Switching on the BDU

Use ON/OFF switch on the BDU's front panel. It normally takes about 1.5 to 3 minutes for the whole UE to be powered up.

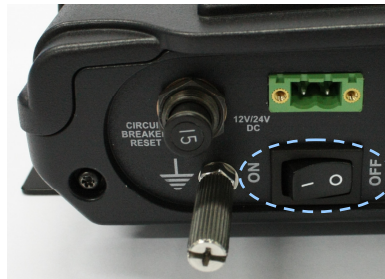

Wait for all LED indicators to turn green.



LED Name	Status	Meaning
TERMINAL	Steady Amber	BDU is powering up.
	Steady Green	BDU has powered up successfully.
	Steady Red	BDU detects failure.
	Blinking Amber	Switching OFF BDU.
ANTENNA	Steady Amber	ADU is powering up.
	Steady Red	ADU is not OK/Error.
	Blinking Amber	ADU is calibrating.
	Blinking Green	Terminal performs satellite search.
REGISTERED	Steady Green	ADU has locked on to the satellite.
	Steady Amber	Attempting network registration.
	Steady Red	Network failure/Error.
	Blinking Amber	Ready for voice only.
	Blinking Green	Ready for packet data only.
	Steady Green	Ready for all. (Voice and Data)

Formatted: Not Highlight



### 4.3 Settings on Web Console

#### 4.3.1 Activating on Web Console

Open the web browser (for example: Internet Explorer, Google Chrome or Firefox.) and type **<http://192.168.1.35>** in the Address field.

Username and Password will be prompted.

Default Username : **admin**  
Password : **1234**

Username:  

Password:

Click “**Login**” after entering the Username and Password.

The Web Console will appear. The UE will proceed automatically to “**Checking PIN status**” followed by “**Antenna pointing**” and then registering to the network (upon power on).

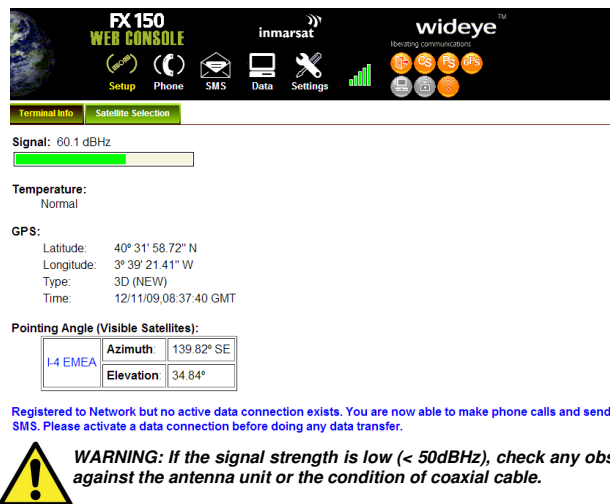

**FX 150 WEB CONSOLE** Inmarsat wideye™  
Setup Phone SMS Data Settings

Terminal Info Satellite Selection

Signal: 60.1 dBHz

Temperature: Normal

GPS:  
Latitude: 40° 31' 58.72" N  
Longitude: 3° 39' 21.41" W  
Type: 3D (NEW)  
Time: 12/11/09,08:37:40 GMT

Pointing Angle (Visible Satellites):

I-4 EMEA	Azimuth	139.82° SE
	Elevation	34.84°

Registered to Network but no active data connection exists. You are now able to make phone calls and send SMS. Please activate a data connection before doing any data transfer.

**WARNING: If the signal strength is low (< 50dBHz), check any obstruction against the antenna unit or the condition of coaxial cable.**

Upon successful registration, with all three BDU's LED indicators which are in green, the UE will be ready for normal operation.

### 4.3.2 Satellite Selection

The latest generation of Inmarsat FBB satellites which are located directly over the equator at:

- I-4 Americas Satellite at 98° W Longitude
- I-4 Asia-Pacific Satellite at 143.5° E Longitude
- I-4 EMEA Satellite at 25° E Longitude

The default Satellite Selection is in **Auto** mode. In **Auto** mode, the UE will scan all the visible satellites and track the satellite with the most optimum elevation angle or the last used satellite.

#### Note:

Changing the satellite selection will terminate any existing active voice/fax call or data connections.

Follow these steps to change your satellite selection:



➡ Click "**Satellite Selection**" to view the visible satellites.

The visible satellites will be displayed for your selection. It also displays the satellite information that your ADU antenna is locked on to.



- ➡ Click on your choice of visible satellites.
- ➡ Click "**Select**" to point the antenna to the selected satellite in exclusive mode. The satellite selection will be saved and each time you power up the UE, the satellite selection choice will remain until you make the next selection change. The UE will track the newly selected satellite even if the elevation angle is not optimum. Click "**Refresh**" to refresh the Satellite list.

### 4.3.3 Data Connection Settings



Click  on the web console.

Click “**Primary Profiles**” and set the following:

- Enable checkbox of “**Set as default**” and ensure “**Standard**” in the Profile Name.
- Enable radio button of “**SIM**” of Access Point Name (APN).
- Enable radio button of “**Dynamic IP address**” and “**User Header Compression**” of IP configuration.

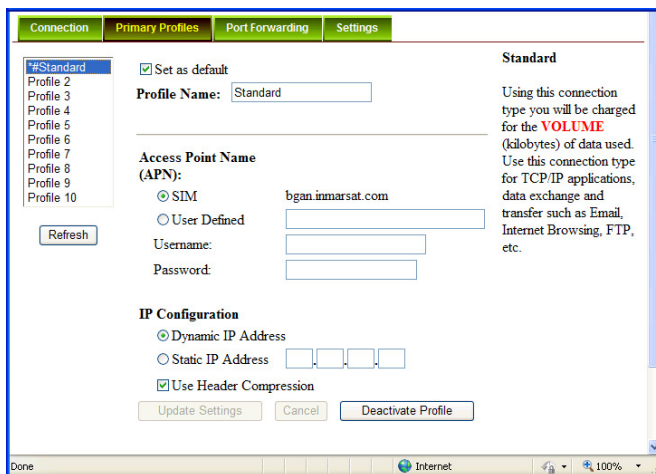

**Note:**

The Standard profile is set as the default primary profile and the default connection type is standard (this is charged by the volume [in kilobytes] of data used).

Under IP Configuration, the **Dynamic IP Address** is selected by default and the Header Compression checkbox is enabled as default.

Click “**Settings**” and set the following:

For the data connection, under the Ethernet mode, enable radio button of “**Router Mode (Multi-User)**” which is with NAT/PAT enabled for multi-user.

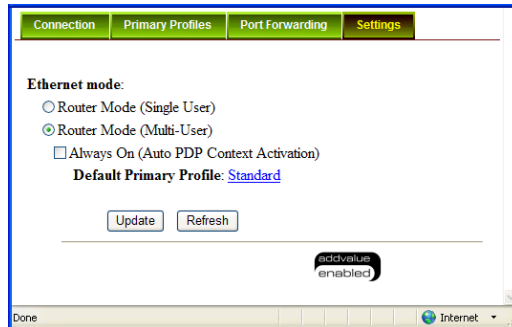

**Note:**

**The Router settings cannot be changed while the Data connection is active. The Data session must be first disconnected.**

Click **“Always On (Auto PDP Context Activation)”** checkbox if it is required to get the standard IP Data connection to be reconnected automatically in the event the connection is disconnected without user intervention, i.e. antenna blockage, etc.

Click **“Update”** to allow the selection to take effect.

- Click **“Refresh”** to query the current mode.

Click **“Connection”**

To activate the PDP context, click **“Activate Default Profile”**

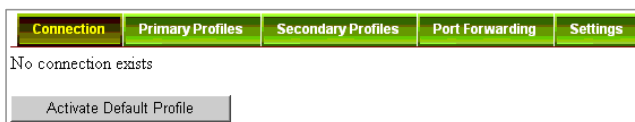

After about 30 to 40 seconds, the data connection will be activated with a notification of the public IP address assigned to the active data connection. An user may now browse the internet, do file transfer (FTP) or run any IP-based application services.

To disconnect the data connection, click **“Disconnect”**.

The PDP context will be deactivated.



### 4.3.4 GPS Setting



Click **Settings** and then click “**Admin**”.

Click **GPS Output** box and ensure radio button of “**Output GPS Data (NMEA @ 9600bps)**” is enabled.

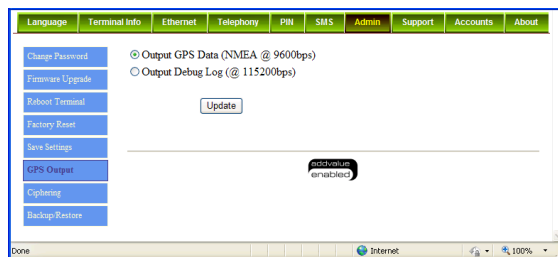

By default, the UE BDU outputs the GPS data in NMEA format via the **NMEA 0183 Connector for GPS output**.

### 4.3.5 Save Setting

It is recommended to save the recent setting changes. To save the recent changes, click “**Save Now**”.

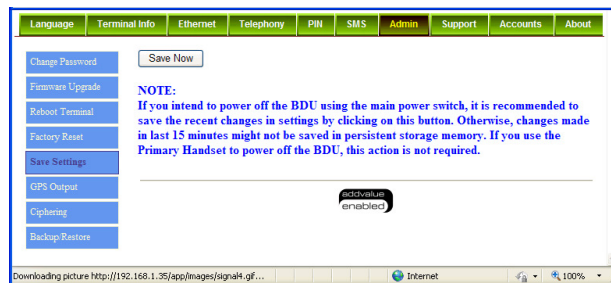

**5 GLOSSARY**

AC	Alternating Current
ADU	Above Deck Unit
BDU	Below Deck Unit
DC	Direct Current
FBB	FleetBroadband
GPS	Global Position System
GPIO	General Purpose Input/Output
UE	User Equipment

**APPENDIX A OUTLINE DRAWINGS**

**A-1 FB 250+ ADU's Outline Dimensions**

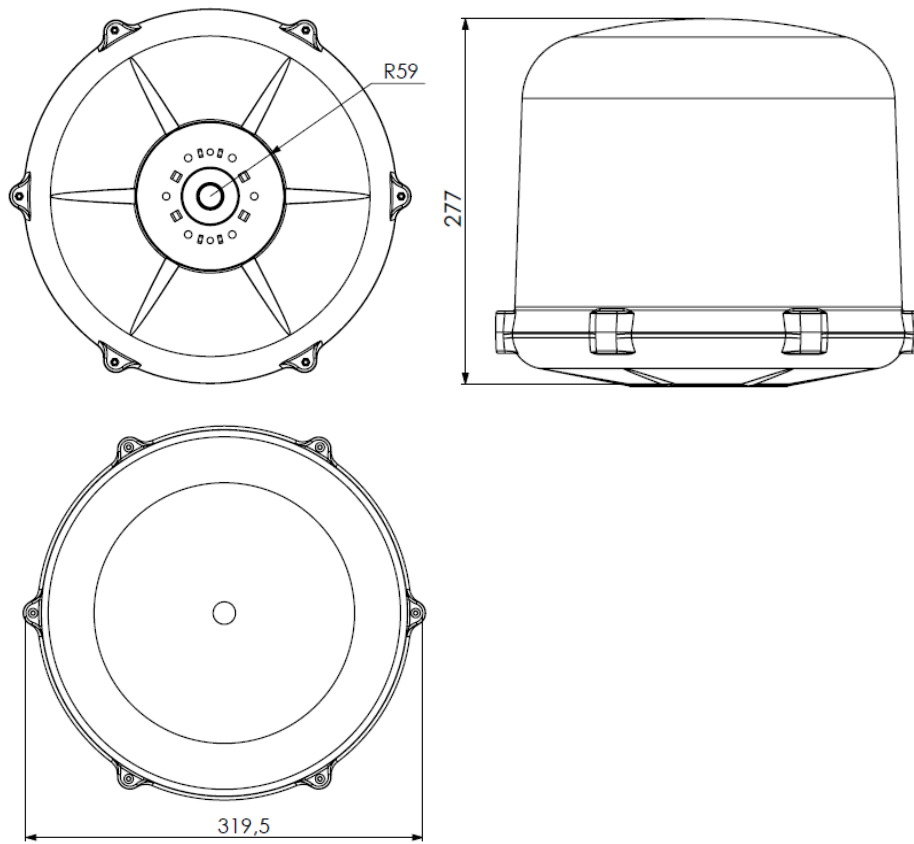

Weight: 3 kg.  
Dimensions are expressed in terms of mm.

**A-2 FB 250+ ADU's Hole Pattern (Cut-out Holes)**

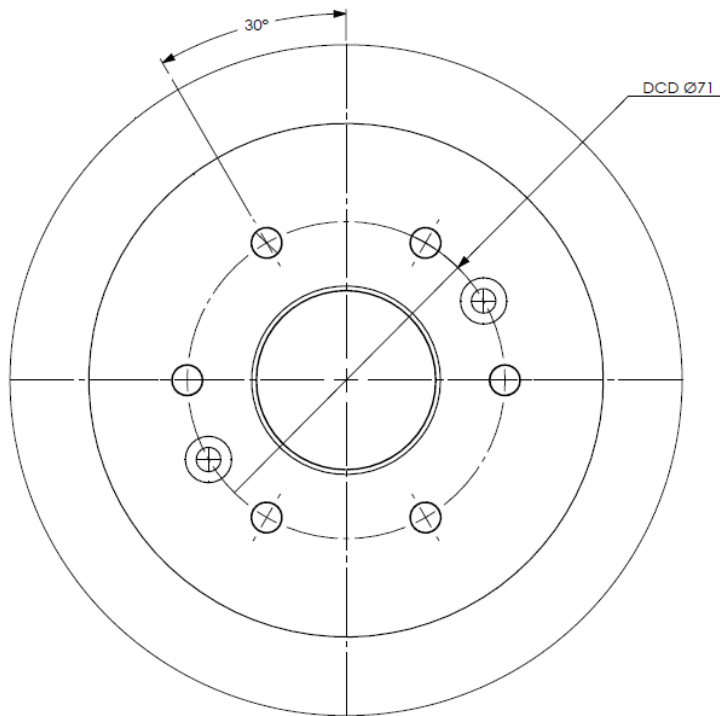

Dimensions are expressed in terms of mm.



**A-5 FB 250+ BDU's Outline Dimensions**

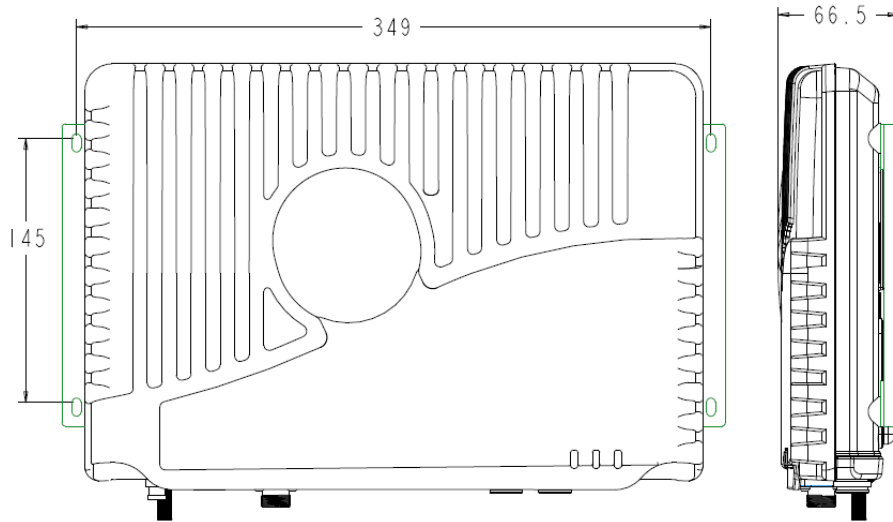

Dimensions are expressed in terms of mm.

**A-6 Primary Handset's Outline Dimensions**

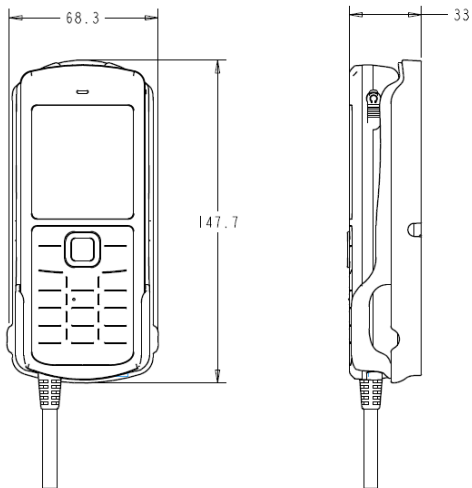

Dimensions are expressed in terms of mm.